



KONICA MINOLTA

# MULTI GLOSS 268 (20°, 60°, 85°) UNI GLOSS 60 (60°)

Makes its debut with more multifunction to achieve the effective gloss measurement.

- It has data compatibility with the previous MULTI GLOSS 268 / UNI GLOSS 60, and improves repeatability and reproducibility.

- Approx. 10,000 measurements are available with one AA(R6) size alkaline battery.

NEW PRODUCT

Large screen size and easily viewable liquid crystal display.

Easy operation with mode scroll wheel.

By operating the mode scroll wheel in accordance with easy-to-understand menu items, you can set a wide array of functions easily.

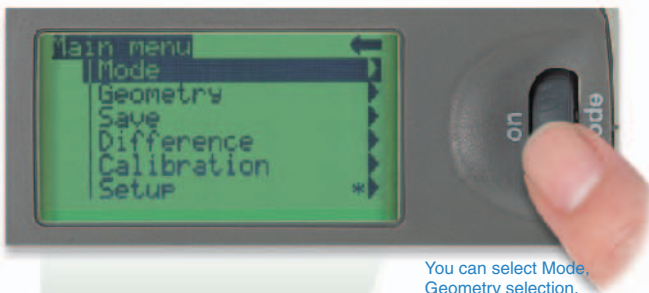

You can select Mode, Geometry selection, Difference, and Calibration from the Main Menu screen.

A wide array of display modes (corresponding to six languages)

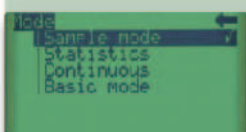

You can measure by selecting Basic mode, Continuous, Statistics from the Mode screen.

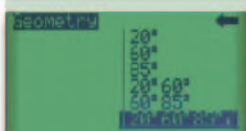

You can select the measurement angle from the Geometry selection screen and display two angles or three angles at the same time. (MULTI GLOSS 268)

Wide measurement range that can be measured from plastic to metal surface with a high gloss finish: 0.0~2,000 GU (in the case of 20°)

The gloss difference measurement of the standard/sample and the PASS/FAIL evaluation.

You can make a pass/fail evaluation by setting the limit value. You can enter the sample name and the standard value name in the measurement result.

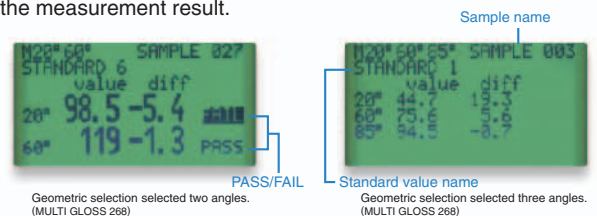

Geometric selection selected two angles. (MULTI GLOSS 268)

Geometric selection selected three angles. (MULTI GLOSS 268)

Autodiagnosis function of calibration

This means a little frequency of calibration and long-term stability. In addition, if the calibration is required, the message will be displayed.

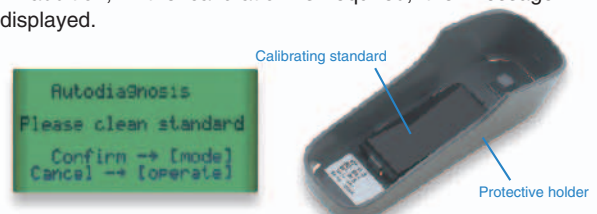

The essentials of imaging

With dedicated Data transfer software (gloss-link), the data management such as data transfer to Excel<sup>®</sup>\* is easy.



OS Windows<sup>®</sup>98/2000/Me/XP, Windows NT<sup>®</sup>4.0

\* Microsoft Excel<sup>®</sup> 97 or higher.  
Windows<sup>®</sup>, Windows NT<sup>®</sup> and Excel<sup>®</sup> is a trademark or registered trademark of Microsoft Corporation of America or its subsidiaries.

## Dimensions

Units : mm

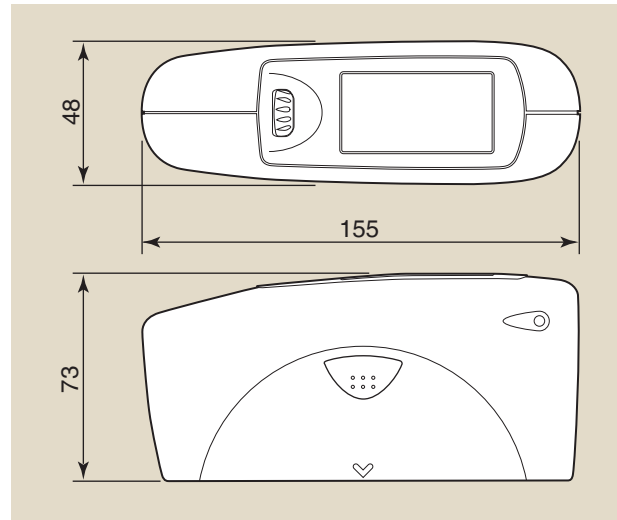

## Specifications

Model	MULTI GLOSS 268	UNI GLOSS 60
Measurement geometry	20°, 60°, 85°	60°
Size of measurement spot	20° : 10 X 10 mm 60° : 9 X 15 mm 85° : 5 X 38 mm	60° : 9 X 15 mm
Standard compliance	ISO 2813, ISO 7668, ASTM D 523, ASTM D 2457, DIN 67 530, JIS Z 8741, BS 3900, BS 6161(Part 12)	
Measurement range	20° : 0.0~2,000 GU 60° : 0.0~1,000 GU 85° : 0.0~160 GU	60° : 0.0~1,000 GU
Resolution	0.0~99.9 GU : 0.1 GU 100~2,000 GU : 1 GU	
Measurement precision	[Repeatability] 0.0~99.9 GU : 0.2 GU 100~2,000 GU : 0.2% of reading [Inter Instrument agreement] 0.0~99.9 GU : 0.5 GU 100~2,000 GU : 0.5% of reading	
Memory	999 measurements with date and time	
Difference measurement	Memory for 50 standard	
Battery performance	Approx. 10,000 measurements (when using 1.5 V AA(R6)size alkaline battery)	
Measurement time	0.5 seconds (each measurement)	
Power OFF	Auto : 10~99 seconds select	
Languages	English, Spanish, German, French, Italian, Japanese	
Measurement mode	Normal mode (Sample mode, Statistics, Continuous, Basic mode), Difference mode	
Interface	RS-232C format	
Operating temperature /humidity range	15 to 40°C relative humidity 85% or less (at 35°C) with no condensation	
Storage temperature /humidity range	-10 to 60°C relative humidity 85% or less (at 35°C) with no condensation	
Power supply	1.5 V AA(R6)size alkaline battery	
Dimensions	155(W) X 73(H) X 48(D) mm	
Weight	400 g	

## Accessories

Model	MULTI GLOSS 268	UNI GLOSS 60
Standard accessories	Calibration holder TRI (High gloss tile) PC-cable Carrying case Data transfer software (gloss-link) 1.5 V AA(R6)size alkaline battery	Calibration holder 60° (High gloss tile)
Optional accessories	Checking standard TRI (3 semi gloss tiles 20, 60, 85°) Checking standard mirror (3 tiles 20, 60, 85°) USB-adaptor AC adaptor	Checking standard 60° (High and semi gloss tile)

Note : The specifications described in this document are subject to change without notice.

MULTI GLOSS 268 / UNI GLOSS 60 conforms with international specifications ASTM D 523, DIN 67 530, ISO 2813.

ASTM DIN ISO



### SAFETY PRECAUTIONS



To ensure correct use of the instrument, please adhere to the following.

- Before using the instrument, be sure to read the instruction manual.
- Always use the specified power. Use of inappropriate power may result in fire or electric shock.

### KONICA MINOLTA SENSING, INC.

Konica Minolta Photo Imaging U.S.A., Inc.  
Konica Minolta Photo Imaging Canada, Inc.  
Konica Minolta Photo Imaging Europe GmbH  
Konica Minolta Photo Imaging France S.A.S.  
Konica Minolta Photo Imaging UK Ltd.  
Konica Minolta Photo Imaging Austria GmbH  
Konica Minolta Photo Imaging Benelux B.V.  
Konica Minolta Photo Imaging (Schweiz) AG  
Konica Minolta Business Solutions Italia S.p.A.  
Konica Minolta Photo Imaging Svenska AB  
Konica Minolta Photo Imaging (HK) Ltd.  
Shanghai Office  
Konica Minolta Photo Imaging Asia HQ Pte Ltd.  
KONICA MINOLTA SENSING, INC. Seoul Office

### 3-91, Daisennishimachi, Sakai.Osaka 590-8551, Japan

725 Darlington Avenue, Mahwah, NJ 07430, U.S.A. Phone: 888-473-2656 (in USA), 201-529-6060 (outside USA) FAX: 201-529-6070  
1329 Meyerside Drive, Mississauga, Ontario L5T 1C9, Canada Phone: 905-670-7722 FAX: 905-795-8234  
Europaallee 17, 30855 Langenhagen, Germany Phone: 0511-740440 FAX: 0511-741050  
Paris Nord II, 385, rue de la Belle-Etoile, B.P. 50077, F-95948 Roissy C.D.G. Cedex, France Phone: 01-49386550 / 01-30866161 FAX: 01-48638069 / 01-30866280  
Precedent Drive, Rooksley Park, Milton Keynes United Kingdom Phone: 01-908200400 FAX: 01-908618662  
Amalienstrasse 59-61, 1131 Vienna, Austria Phone: 01-87882-430 FAX: 01-87882-431  
Postbus 6000, 3600 HA Maarssen, The Netherlands Phone: 030-2470860 FAX: 030-2470861  
Riedstrasse 6, 8953 Dietikon, Switzerland Phone: 01-7403727 FAX: 01-7422350  
Via Stephenson 37, 20157, Milano, Italy Phone: 02-39011-1 FAX: 02-39011-219  
Solnastrandvägen 3, P.O.Box 9058 S-17109, Solna, Sweden Phone: 08-627-7650 FAX: 08-627-7685  
Room 1818, Sun Hung Kai Centre, 30 Harbour Road, Wanchai, Hong Kong Phone: 852-34137508 FAX: 852-34137509  
Rm 1211, Ruijin Building No.205 Maoming Road (S) Shanghai 20020, China Phone: 021-64720496 FAX: 021-64720214  
10, Teban Gardens Crescent, Singapore 608923 Phone: +65 6563-5533 FAX: +65 6560-9721  
801, Chung-Jin Bldg., 475-22, BangBae-Dong, Seocho-ku, Seoul, Korea Phone: 02-523-9726 FAX: 02-523-9729